

Raptor G4 Wind Turbine Blades and Hub Kits

Models: RAPTORG4-BLADE, MWHUB

Date: 08/2018

Page: 1 of 1

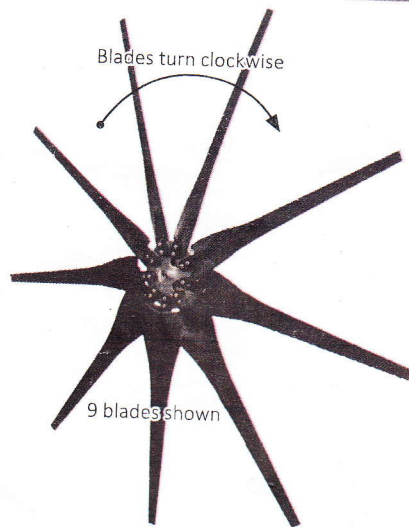

Flat side of the blade faces the wind

WIND

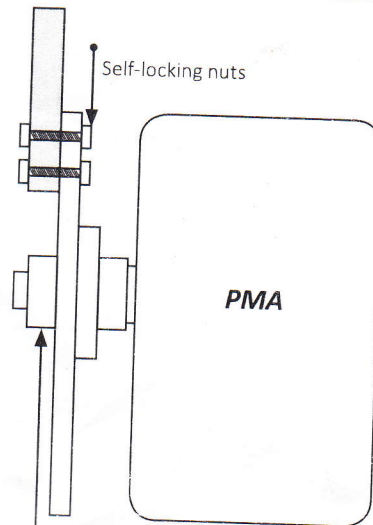

CAUTION

Do not overtighten the center nut. When the lock washer is flattened and snug give it another $\frac{1}{4}$ turn or so. You want the nut very tight but do NOT splay out or separate the lock washer with excessive force. The nut is self-tightening in the wind if it begins tight.

All Raptor blades have a flat side that must face the wind. On the Generation 4 (G4) blades, the words "Raptor USA" must be showing when assembly is complete. The bolts are meant to be snug in the hole, but if the bolts fit too tightly, you can re-drill using a $\frac{1}{8}$ " drill bit. Use the provided self-locking nuts or the blades could come loose. The blades are flexible and you might receive them slightly bent. If this is the case, install them anyway. They will self-straighten in the wind after a couple of weeks and stay this way permanently. ONLY tighten the blade bolts to 5 foot pounds of torque or the blade handles will crack!! The wind turbine hubs come zinc-plated and do not require painting.

Warning: The Raptor G4 blades turn very quickly and may cause severe bodily damage if you come into contact with them. Never place a wind turbine near power lines or structures. Place wind turbines high enough to be out of the reach of children and inexperienced persons. Missouri Wind and Solar assumes no liability for injury or damages caused by these blades.

MISSOURI
WIND AND SOLAR

332 Cobble Stone Drive, Seymour, MO 65746
www.mwands.com • (417) 708-5359

Missouri Wind and Solar

Wind Turbine Manual

Introduction

1. Thank you for purchasing a Missouri Wind and Solar wind turbine system. Please be sure to fully read and understand these instructions before installation.
2. Freedom turbines are available in 1600 watt and 2000 watt models in the following voltages: 12V, 24V, 48V. Ensure you have the right turbine by looking on the electrical wiring (“pigtail”) of the turbine for a colored dot: green dot = 12V; no dot/“black” = 24V; grey dot = 48V.
3. DANGER! Turbines output lethal voltage and current levels. Exercise safety precautions.

Tower Considerations

1. An ideal tower is one that allows easy access to the turbine for inspection and periodic maintenance. Common tower designs include a hinge plate at the bottom, which allows the tower to be laid down on the ground. If you choose to use a steel pipe, we recommend several runs of guyed wire to secure the tower.
2. Ensure the tower is 30 feet higher than the nearest obstruction (trees, buildings) in a 100’ radius. Doubling the tower height increases power output by 34% or more. Lower heights may produce less power. This is a function of naturally occurring winds, not the turbine’s performance. However, lower towers may make more sense cost-wise.
3. For towers 60 feet in height, use a minimum of 3/16 inch guy wire cable to support the top of the pole and 1/8 inch to support the middle and/or bottom. 7x7 cable – 7 bundles, made up of 7 individual wires each, twisted together into one rope - is recommended.
4. Wind turbulence will severely reduce power output and is usually caused by structures interrupting and/or blocking clean wind from contacting the blades and tail assembly. This is evident by erratic left-to-right pivoting of the turbine, sometimes with heavy vibrations.
5. Placing your turbine in a low wind area, or a bad location such as a rooftop or behind a building, may still produce power, but at a much lower charging rate. Turbines mounted on rooftops or connected to the end of a building will see considerably less output due to turbulent or “dirty” wind. The higher the better!
6. It is recommended to drive a ground stake at the base of the tower and clamp a 4 gauge wire from the stake to the tower pole. Grounding a battery system is typically done between only the battery negative terminal and a ground stake.

Use 4 gauge wire for the ground. Try not to have sharp bends in the ground wires as lightning can jump out of sharp bends. This is minimal information. Please refer to additional sources for further grounding information.

Blade and Hub Assembly

1. Raptor Generation 4 & 5 blades have a flat face near the blade tip. The flat surface must face the wind. Correctly installed Gen 4 blades will reveal the word “Raptor” on the blade base (see Figure 1). Correctly installed Gen 5 blades will have a notch on the blade base situated on the right side (see Figure 2).



Figure 1

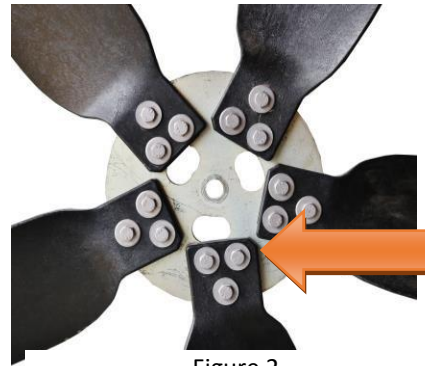

Figure 2

2. The blade bolts are designed to fit tightly. You can re-drill the blade mounting holes using a 1/4” drill bit, if needed. If the holes are grossly off-centered, then seek a replacement before installation.
3. Use the provided self-locking nuts, and ensure the nut is seated completely against the hub (see Figure 3). Torque the blade bolt/nuts to the specifications in the list below after nut is fully seated. Do not overtighten the nuts, as the blades may crack. Failure to adhere to this warning could result in blades coming loose during operation, and possibly causing injury, damage, or death.
 - **Raptor Generation 4 (G4) Blades:** 7 ftlbs
 - **Raptor Generation 5 (G5) Blades:** 10 ftlbs
 - **Falcon Blades:** 15 ftlbs



Figure 3

4. The blades are semi-flexible and may be slightly bent forward, backward, or out of line. The blade will self-straighten over time and remain straight permanently.
5. These blades turn very fast and can cause severe bodily harm. Never place a wind turbine near power lines or structures. Moving structures such as trees sway and grow and can come in contact with the blades, causing damage or loosening or separation of the blades from the hub. Place blades high

enough out of reach of children or inexperienced people. Missouri Wind and Solar, LLC assumes no liability for injury or damage caused by these blades.

6. Inspect your blades and hub mounting fasteners annually for damage, corrosion, and tightness, especially in humid or salty environments. Our blades require no initial or follow-up surface coating. Do not paint the blades; UV protectant protects the blades.
7. Please allow approx. 100 hours of bearing “break in” time. Until then, turbine start up may be slow.

Turbine Wiring

1. The Permanent Magnet Generator (PMG) outputs 3-phase wild AC power. The PMG’s internal wiring connects to a 3-wire bundle (wire size depends on PMG amps and distance between PMG and bridge rectifier), which travels down the tower to the turbine brake, then to the bridge rectifier. The rectifier converts 3-phase wild AC to DC, and its DC output is sent to the divert (charge) controller, then on to the batteries.

NOTE: The PMG’s AC output is 3 hot wires. The PMG cannot be wired directly into a standard household fuse box/service panel with power supplied by the electrical grid or generator. Doing so can result in electrical shock, fire, even death. The PMG must be connected to an AC-to-DC rectifier.

2. Do not use solid wire or undersized wire in any leg of your turbine installation. Solid wire will not twist and flex. Undersized wire acts as a resistor, decreasing current flow and allowing heat build-up, both of which will reduce the turbine’s power output and cause turbine failure. Proper wire selection is based on amps and distance (refer to DC wiring chart). Wire larger than recommended is acceptable. Use appropriate electrical connectors and heat shrink. Make clean and tight electrical connections. Moderately tug at your connections to check for loose fittings.

Turbine Accessory Assembly

Turbine Brake Switch

1. The brake is an optional component in a turbine system, but important in that it secures the blades from turning when raising/lowering the tower.
2. The brake is the first component to receive the 3-phase AC output of the turbine. Usually mounted near the bridge rectifier and divert controller, to minimize length of DC cabling.
3. The brake switch has 3 black wires and 3 red wires. Connect black wires to the turbine’s AC output; connect the red wires to the bridge rectifier. Keep switch in either the “run” or “brake” position, never let the turbine free spin. The only exception is if the fuse or breaker blows. It is better to allow a free spin than to burn out the generator head.

NOTE: Avoid braking your turbine in winds greater than 20 MPH. Braking in these conditions can cause the turbine stator to overheat and burn up. The brake is normally used during maintenance and turbine/tower erection or takedown. Never allow the turbine to free-spin in high winds, as the blades can self-destruct and open turbine voltages can be lethal and damaging to the turbine at high RPMs. It is best to leave the brake in the “On” position and let the divert controller and diversion load regulate the turbine.

Bridge Rectifier (Figures 6 & 7)

Refer to the included rectifier instruction sheet for more detailed information.

1. The rectifier will get warm during normal operation, so it is mandatory to mount the rectifier onto a metal surface for heat dissipation. Aluminum makes the best heat sink, the larger the better.



Figure 6 – 90A for 12 & 24V PMGs



Figure 7 – 50A for 48V PMGs

2. The rectifier is normally mounted below the brake switch, so the 3 red wires from the brake have a straight run to the rectifier. **Make sure the rectifier positive and negative terminals are connected correctly by looking for the + and - symbols. Do not reverse the connections.**
3. Use 3/8" female spade terminals for the AC wires, or terminal lugs with a #8 screw for 90 amp rectifier or #5 screw for 50 amp rectifiers to attach to the rectifier's metal tabs. A mechanical joint that is also soldered will last a long time and provide superior electrical conductivity. If you do not solder the connection, we recommend dielectric grease.
*Do not overheat the rectifier during soldering, allow no more two seconds per terminal maximum.
4. Inspect all connections on the bridge rectifier and ensure they are not coming in contact with the rectifier housing which is conductive aluminum. This will cause serious issues and possible burn up.
5. Always place an inline fuse or breaker directly after the rectifier on the positive DC side.

Freedom II fuse sizes: 12V – 120A; 24V – 80A; 48V – 40A

Freedom I fuse sizes: 12V – 100A; 24V – 60A; 48V – 30A

NOTE: All electrical components may become warm or even hot. Do not install directly on or around flammable material, such as foam insulation boards or near stored gasoline cans or other flammable liquids. Installations should be out of reach of children and pets.

*Allow 10 inches of space around components, especially a dump load.

Diversion (Dump) Load

1. Normally mounted adjacent to the divert controller.
2. Install the divert load as per its instructions, unless it conflicts with another set of instructions such as your charge controller instructions. Keep in mind, your diversion load relay is limited to 120 amps maximum.

NOTE: Diversion load resistors can get VERY HOT and dissipate excessive heat, especially during high winds when continuous dumping of energy can occur. NEVER place anything flammable near the dump load. Remove all packing material from the unit and always mount resistors on a fire-proof surface.

Divert Controller ("Charge Controller")

1. Mount divert controller out of the weather, near the battery bank.
2. Allow room adjacent to the divert controller to mount the diversion load. Space adjacent components several inches from the divert controller or install a heat proof barrier.

Wiring

1. Proper wire size is critical for system operation and safety. [Use our DC wire chart](#) to select the correct wire size for your installation.

NOTE: 66A also represents the maximum circuit breaker/fuse protection required. For systems required to comply with the National Electrical Code, multiply 66A by 1.56. [See the Midnite Solar DC breakers at www.mwands.com](http://www.mwands.com) for 0-150V DC systems.

- a. Assuming the total distance between the first DC component (bridge rectifier) and the last DC component (battery bank) is less than 15 feet, then #4 AWG DC wire is sufficient. DC wiring will be used between the following components:
 - 1) Rectifier to divert controller
 - 2) Divert controller to diversion load
 - 3) Divert controller to battery bank

Turbine Assembly

1. Tail Assembly (Figures 10 & 11)

- a. Attach left and right tail arms (Figure 10).
NOTE: For dual-arm tail, ensure tabs face inward.
 - b. Attach clamp connector to L-bracket.
 - c. Attach L-bracket to PMG mount.
NOTE: L-bracket should NOT touch top of tower pole (1 1/2" steel pipe).
- a. Attach tail fin. **Secure all bolts to a torque of 15 ftlbs.**

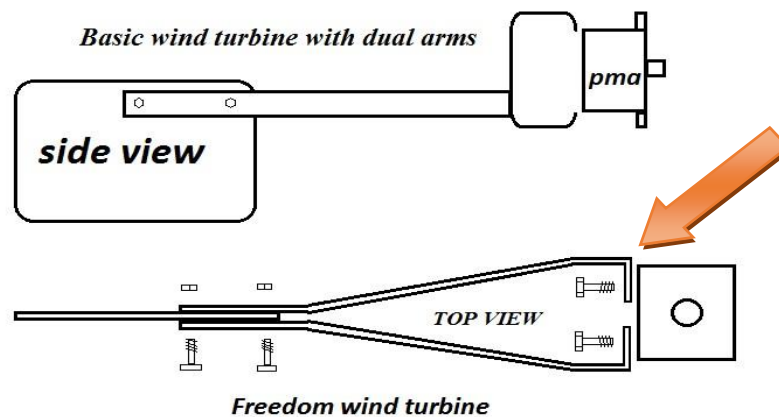

Figure 10

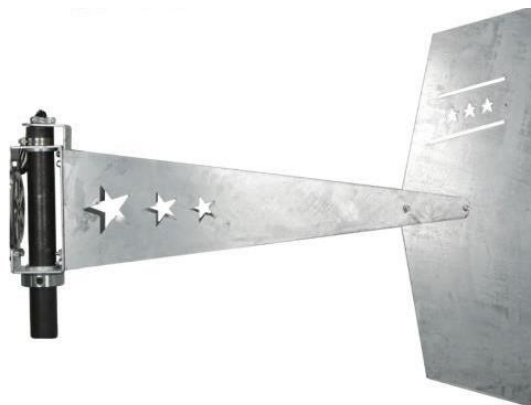

Figure 11

2. Pole Prep

- a. If your wind turbine includes a lock collar, slide collar over steel pipe (see Figure 12). Secure two set screws, do not overtighten. Doing so may cause the pole to lose its round shape.

NOTE: Position lock collar so L-bracket on mount assembly does not touch pipe. See Figure 13.

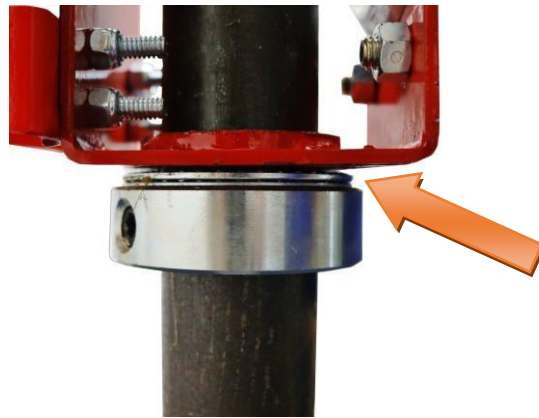

Figure 12

- b. If supplied, place nylon washer or optional yaw bearing on top of lock collar (Figure 12).

NOTE: Your tower must be level and plumb, especially when using the yaw bearing.

- c. Slide mount and tail assembly onto pipe, resting on top of nylon washer/yaw bearing. **Do not use a lock collar at the top of your pole.** Doing so may cause the pole to be out of round and prevent the turbine from pivoting freely. Use the supplied hose clamp instead. **WIND TURBINES INCLUDE ONE LOCKING COLLAR ONLY!**



Figure 13

3. Turbine / Permanent Magnet Generator (PMG)

- a. Attach PMG to mount with 4 bolts. **Tighten bolts to a torque of 20 ftlbs.** Figure 14 is an illustrated parts breakdown drawing of our DC PMA, which reflects 2 bolts for mounting versus 4. Otherwise, all other components assemble similarly.

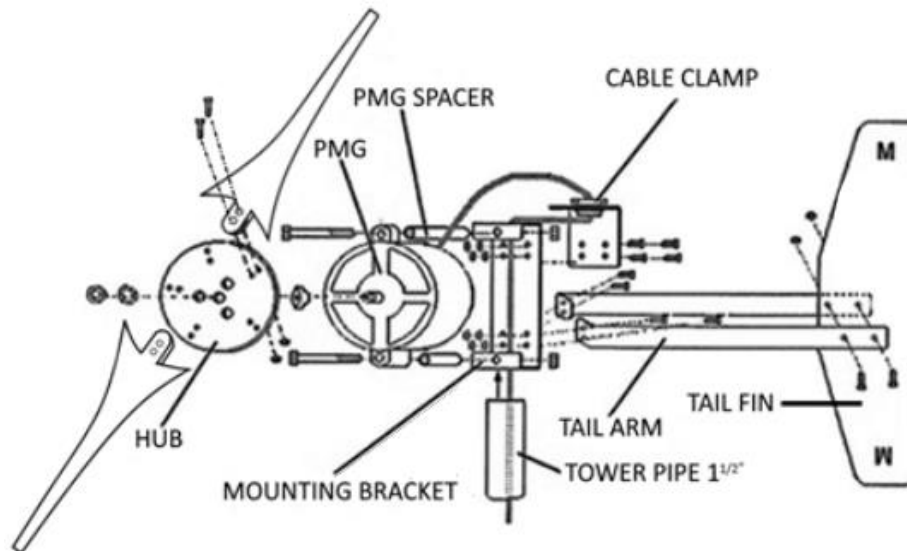

Figure 14

4. Blades and Hub

- a. Remove nut and lock washer from PMG rotor shaft. Ensure hub spacer, as seen in Figure 3, remains in place. Remove the three bolts from the spacer/stabilizer.
- b. Place hub on rotor shaft, aligning the slot for the key. Reinstall three bolts through the hub into the stabilizer. Reinstall lock washer and nut, tighten using wrench and Allen wrench, as seen in Figure 15. **Tighten to a torque of 60 ftlbs.**



Figure 15

NOTE: Extreme overtightening is not necessary because the rotation of the hub and blades helps keep the nut tight. The keyed shaft and bolts holding the hub to the spacer keep the blades secure to the PMG.

NOTE: Set brake switch set to “Brake” or leave turbine/tower on the ground before installing hub/blade assembly. DO NOT install the turbine onto the tower during windy conditions. Ensure the blades are stationary (not rotating) before connecting the battery bank to the divert controller. This can be accomplished by either using the brake switch or installing the hub and blade assembly AFTER making the electrical connections.

Operation

1. Assuming the tower is erected and level, the turbine is installed, and all electrical connections are made, toggle the brake switch to the “On” position. *Make sure to always connect charge controllers to your batteries before connecting the wind turbine.*
2. Monitor battery bank voltage as displayed on the divert controller. Ensure it reads close to the bank voltage. For example, if you planned to have a 24V bank and the divert controller reads 11.7V, then something is wrong.
3. If you have an ammeter, watch for current flow when the turbine blades spin.
4. It is a good idea to watch/listen (solenoid clicks audibly) to the divert controller during high winds or when the battery bank is nearly full to ensure the divert controller “dumps” at the preset voltage level. For a 12V bank, dump occurs at 14.4V-13.6V.

Troubleshooting Guide

NOTE: Before you call or e-mail, PLEASE read and understand all the PMG and associated components’ instructions. PLEASE read the entire troubleshooting section. PLEASE have a list with all the products’ model numbers (i.e., purchase invoice) when you call for help. It is easier and quicker for us to troubleshoot your issues if you e-mail us pictures of your entire system, from the PMG to the inverter, and everything in between.

1. Wind turbine output voltage varies based on wind speed, battery bank voltage, and blade count (torque). We advise measuring volts and current on the DC side of the bridge rectifier using DC meters, versus measuring on the AC side. Only check the DC output at the rectifier when the turbine is disconnected from the charge controller and during no high-wind conditions.

NOTE: Disconnecting turbine from battery bank during high winds may allow turbine to free-spin wildly, which can damage the turbine and/or blades.

2. The turbine will only charge a battery when the turbine output exceeds the battery bank voltage. It is possible to see your battery voltage rise quickly with a strong wind gust, then fall back to the original voltage level, or slightly above that level.
3. Mismatched batteries: Using old batteries with new, large batteries with small, or a mismatched battery bank of any kind is not optimal and will result in an undercharged battery bank. In this case, lack of charging is not a fault of the wind turbine. Additionally, the batteries will not last very long in most cases.
4. To determine the amount of power being produced by your turbine at any one moment, multiply the battery bank voltage by the turbine’s current output to determine watts produced. Some divert controllers have a built-in ammeter; otherwise, use a shunt with ammeter inline on the DC positive wire between the rectifier and the divert controller.
5. A slight hum from the turbine is normal.
6. If the turbine severely shakes or vibrates, this is usually caused by one or more unbalanced blades or a blade(s) installed backwards. If you have a bent blade that will not straighten itself over time, heat the

blade using a heat gun or hair dryer until it is extremely warm, but not melting. While the blade is hot, put a weight on the middle of the bend and let the blade completely cool. All Raptor blades have a twist from the butt to the tip, and this is normal. Bent blades, however, rarely create problems with turbine operation.

7. When the voltage of your battery bank rises, it takes more wind (torque) to continue charging the bank. Our wind divert controllers are programmed to prevent overcharging the battery bank. Battery bank and divert voltages:
 - 12V Bank: 50% - 12.3V; 100% - 12.8V; Divert – 14.4V
 - 24V Bank: 50% - 24.6V; 100% - 25.6V; Divert – 28.8V
 - 48V Bank: 50% - 49.2V; 100% - 51.2V; Divert – 57.6V
8. When a turbine outputs power, it creates heat. Sustained operation in high winds can cause heat build-up and power loss, until the wind slows and the turbine cools down.
9. Check the wire, especially near connection points, and note how hot it is. If it is hot to the touch, then you are using more amperage than the wire can handle. You will need to add more copper by doubling up the wire or replacing it with larger cable.
10. A poor, sloppy, dirty, or loose connection typically causes heat buildup especially near the connection point and will also result in significant power loss.

Troubleshooting common problems:

a. Turbine does not charge battery bank:

- 1) Verify the PMG's voltage matches the battery bank voltage (i.e. 12V PMG and 12V battery).
- 2) Ensure wire size is correct between all DC components, all electrical connections are correct and tightly connected, crimped, or soldered.
- 3) Ensure DC positive and negative from turbine (via divert controller and/or rectifier, depending on divert controller) are connected to the "Master Positive" and "Master Negative" battery bank terminals. See Figure 16.

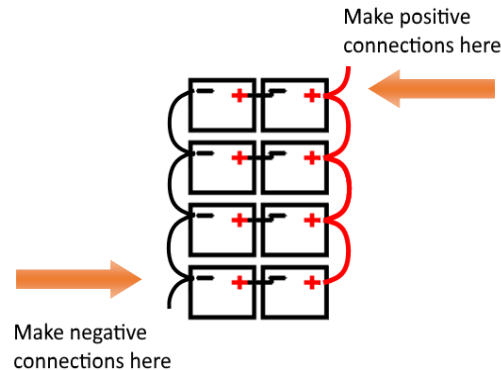

Figure 16

- 4) Ensure wind speed is sufficient to produce power, usually 6 MPH or greater.
- 5) If starting out with a fully charged battery bank, sometimes it helps to place a load on the bank, draw down the voltage, then check for turbine power production.
- 6) Use DC ammeter (or shunt with gauge) to check for current off any DC positive wire between rectifier and battery bank. Amount of current depends on wind speed. With turbine spinning and no current, check electrical connections.
- 7) When your battery voltage rises it takes more wind to charge. A full battery bank at rest is 12.6V, 25.2V, etc. A charge controller will stop charging at 14.4v, 28.8v to keep batteries from being ruined.
- 8) When a wind turbine outputs power it creates heat, which can build up. Open faced PMA/PMG wind turbines work best to keep themselves cool. Too much sustained output can cause heat buildup and power production to decrease until the wind slows for some time.
- 9) There may be an open circuit (poor or no connection) on one of the phases from the wind turbine. Check connections between the stator, jack, connection to wire, connection from wire to brake switch (if applicable), brake switch internal contacts, brake switch to rectifier, rectifier internals, and so on down to the batteries. It is easiest to begin checking connections at the lowest point and work upward.
- 10) Please make sure your rectifier positive and negative connections are correct. Note the actual + and - symbols and make sure they connect to the charge controller accordingly.

Wind Turbine Wattage & Voltage	Dump Load Size
1600W in 12V	600W – 1200W
1600W in 24V	600W – 1500W
1600W in 48V	600W – 1500W
2000W in 12V	1200W - 1500W
2000W in 24V	1200W – 1500W
2000W in 48V	1200W – 1500W

NOTE: When the divert controller dumps, the battery bank is discharging energy to the diversion load (resistors). Divert controllers will measure battery voltage levels every 5 seconds, on average. When the battery voltage drops below the dump set point, the divert controller stops the dump. During the dump, the PMG current is also sent to the dump load, but the function is primarily to drain the battery bank's excess voltage. Therefore, an undersized diversion load takes much longer for the battery bank to lower its voltage level, thus the divert controller operates longer and gets hot.

NOTE: Use maximum dump load figures above when using an approved MPPT charge controller, if you experience regular high winds, or have AGM or gel batteries or your batteries may overcharge.

c. Blades not spinning or seem unbalanced

NOTE: Check the ohms at the rectifier ONLY in a no-wind condition.

Ensure your test meter has a fully charged battery or it will read incorrectly. ONLY check the ohms (Ω) when the turbine is not spinning or even slightly rocking back and forth and the DC side of the rectifier is disconnected.

If the bridge rectifier is warm or hot when the turbine has been idle for an extended period, then the rectifier either is defective or has the wrong polarity connected on the DC side.

You may need to check the ohms (Ω) of the 3 separate phases. You can do this at the 3 phase side of the rectifier with your total length of power cord connected to the wind turbine.

The ohms of the 3 PMG's Stators:

- 12v is 0.3 ohm phase to phase, 24v is 1.8 ohm, 48v is 6.7 ohm.
 - You would check the ohms between the 3 phases on the AC side phase 1+2, 1+3, 2+3.
- 1) Make sure no wire's copper is touching another. Check the ohms/resistance between phase 1 + 2; 1 + 3; 2 + 3. If all read the same, for example 2 ohms each, then there is no short between phases either in the rectifier, power cord, or copper windings (stator inside turbine motor (PMA/PMG).
 - 2) If you read 20 ohms, 0 ohms, 2 ohms this means you have a phase shorted against another. Shorts will cause havoc on your system and typically a failure (charring, burning) of the stator in the turbine motor. It's like holding the brake pedal and accelerator down on your car at the same time! If you have other 3 phase devices connected before or after the rectifier, check them for shorts as well.
 - 3) Ensure your bridge rectifiers are not wired in series (typically for a Freedom II or dual motor wind turbine). If in series, your turbine motor will produce double the voltage and you will get lower amperage and a noticeably lower speed of rotation from the blades. Optimally, you will wire your rectifiers in parallel and see an increase in power and rotation speed.
 - 4) The sealed bearings may take approximately 100 hours to fully break in and loosen up. Before this break in period, the wind turbine might spin more slowly, especially in very low wind, and hamper startup speed slightly.

Ítem	Solicitud de Compra	Cantidad	Descripción
1.	239698	3 u	<p>AEROGENERADOR DE EJE HORIZONTAL con las siguientes características:</p> <ul style="list-style-type: none"> • Aerogenerador de eje horizontal para intemperie. • Diámetro mínimo del rotor ensamblado de 1.5 metros. • Eje de la turbina de mínimo 12mm. • Potencia nominal de 500W. • Voltaje de operación de 12V. • Con rectificador de puente de 3 fases para convertir a salida de corriente continua. • Con volante para almacenamiento mecánico de energía. • Con cola en acero. • Con control de frenado. • Similar o superior a la marca: Missouri Freedom.

Oferta

Inversión requerida:

Esta sección indica de manera general los costos de los equipos ofertado. Luego se hace un detalle de cada elemento que conforma las partes de los equipos y las características operativas.

Suministro de 3 Aerogeneradores de eje horizontal marca Missouri, modelo Basic Raptor Wind Turbine 7 Blades – 500.

ÍTEM	CANTIDAD	DETALLE	PRECIO UNIT	PRECIO UNIT
1	3	Aerogenerador eje horizontal 500W 7 aspas	\$ 490,00	\$ 1,470,00
			I.V.	\$ 191,10
			TOTAL	\$ 1,661,10

Monto en letras: Mil seiscientos sesenta y un dólares americanos con 10/100

Detalle Aerogenerador:

- Eje horizontal marca Missouri Freedom
- Aspas tipo RAPTORTM para operaciones en condiciones de viento mixtos
- Potencia nominal 500W, esta potencia podría excederse en condiciones de mayores vientos como los presentes en zona 2
- Velocidad de corte cut-off a 3.57 m/s
- PMA VICTORY con eje de 12 mm, 100% rotor zinc plata, con diseño para máximo enfriamiento en operación continua.
- Incluye volante para almacenamiento mecánico de energía
- Cola de aerogenerador de dos brazos, en acero calibre 16, dimensiones 330 mm X 228 mm
- Voltaje de operación 12V.
- Número de aspas 7.
- Rectificador de puente de 3 fases.
- Para convertir a salida de CC.
- Ensamble de aspas con diámetro final 1.52 m
- Vida útil de rodamientos de máquina 125,000 hrs
- Soporte de montaje PMG y cola de turbina eólica de alta resistencia.
- Acabado resistente a la intemperie galvanizado por inmersión en caliente.
- Control de frenado.

MISSOURI
WIND AND SOLAR

Missouri Confederate



Missouri Wind and Solar © 2015

Missouri Confederate



Wind Turbine Specifics	
Available Voltage	12 Volts, 24 Volts, 48 Volts
Available Wattage	500 Watts
Blade Material	Carbon Fiber
Blade Quantity	7 Blades



Missouri Wind and Solar © 2016

Our Basic Raptor Wind Turbine for home, business, or remote use has been upgraded to seven blades. This wind turbine produces 500 watts+ power.

The Raptor Seven Blade Basic is a great wind turbine to start with and is expandable with our blade upgrades and PMA parts.

Uses: Battery or battery bank charging, stackable wind turbine grid tie inverters, direct DC water heating elements, direct DC resistive heating, or other applications where 3 phase AC or DC can be used.

- The 3 phase AC to DC bridge rectifier is built into the case making it a two wire run to your charge controller or batteries but can be removed and installed next to your batteries or inverter for a 3 phase run down the tower (DC model only, AC model comes separate).

Turbine Features:

- Tail fin is 16 gauge steel 13" x 9"
- Assembled blades and hub are 60" diameter
- 125,000 hours+ of rated bearing life
- Output can exceed 500 watts if you have zone 2 winds or above; power rated when using Raptor G4™ blades
- Cut-in speed of only 8 mph! (10 mph for the 48V version)

The turbine comes with:

- (7) Generation 4 Raptor Blades
- Zinc plated 3/16" thick steel hub
- Victory Basic PMA
 - standard 17mm shaft
 - 100% solid core zinc plated rotor design with air flow holes for cooler operation
 - Smoother operation with flywheel power boost
- mounting bracket
- 13" x 9" 16 gauge steel tail fin

- 2 wind turbine tail arms
- and the hardware to bolt those components together

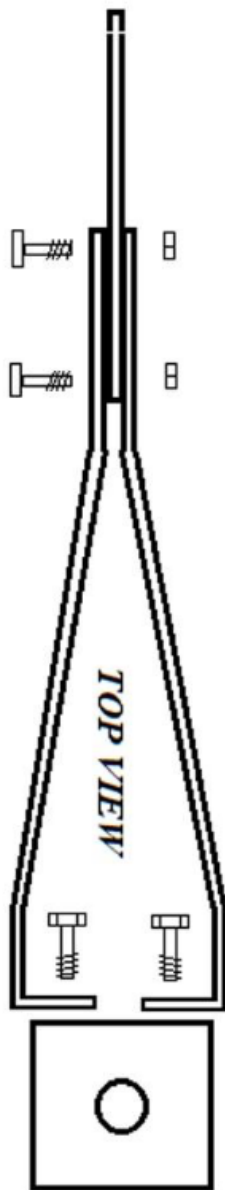

Two Arm Assembly

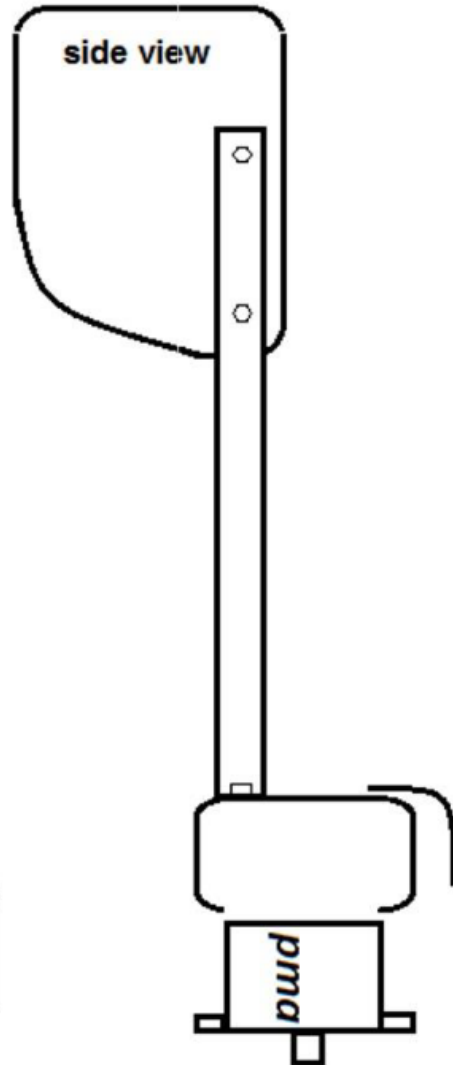

Single Arm Assembly



Missouri Wind and Solar
332 Cobble Stone Drive
Seymour, MO 65746

Telephone
1-(417)-708-5359

Fax
1-(417)-708-5359